

LARYNGO-BRONCHO-OESOPHAGOSKOPIE

LARYNGO-BRONCHO-ESOPHAGOSCOPY

LARYNGO-BRONCHO-OESOPHACOSCOPIE

LARINGO-BRONCO-ESOFAGOSCOPIA

LARINGO-BRONCO-ESOFAGOSCOPIA

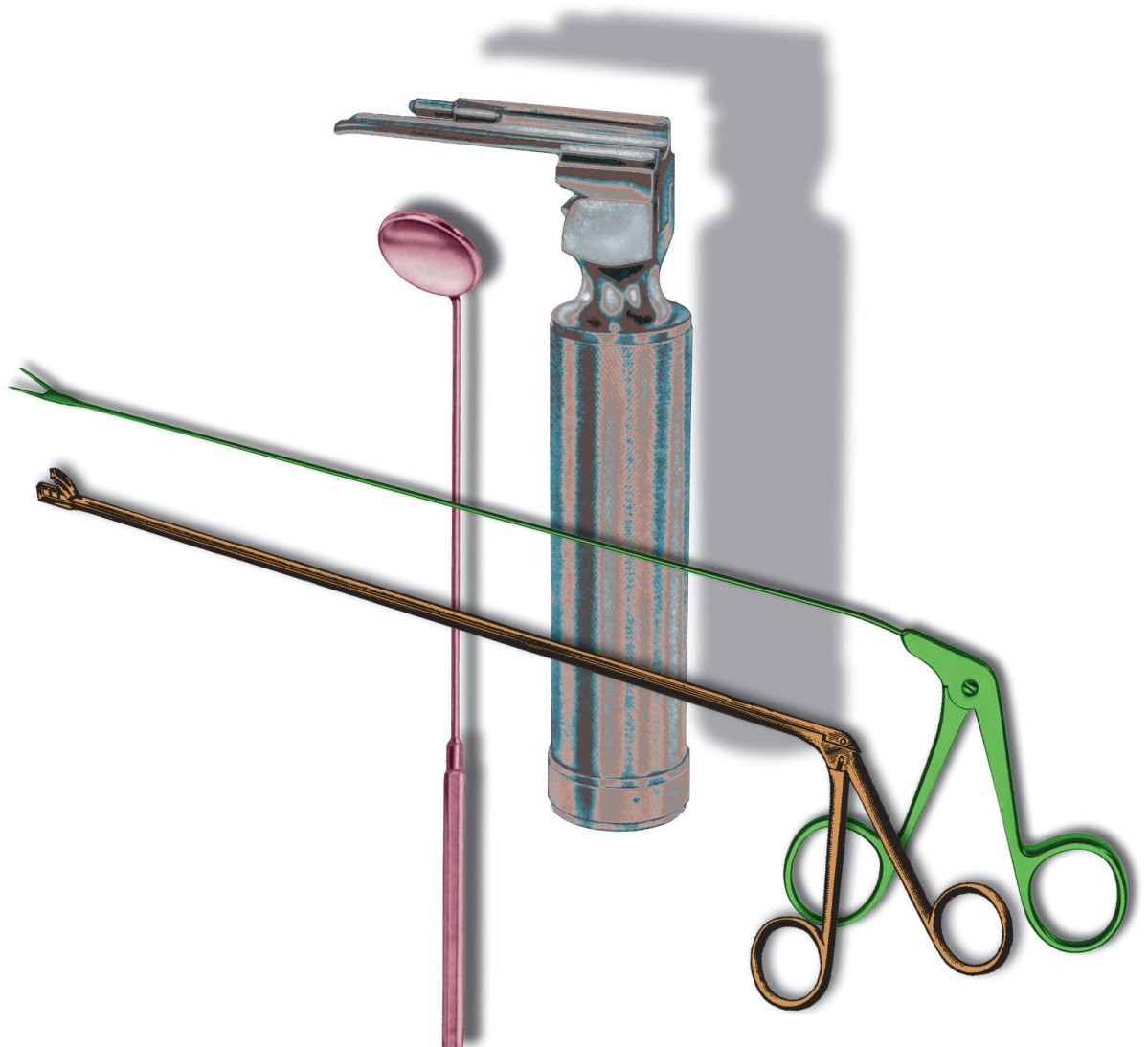

KEHLKOPFSPIEGEL- UND GRIFFE
 LARYNGEAL MIRRORS AND HANDLES
 MIROIRS ET MIROIRS LARYNGIENS
 ESPEJOS Y MANGOS LARINGEOS
 SPECCHIETTI E MANICI LARINGEI

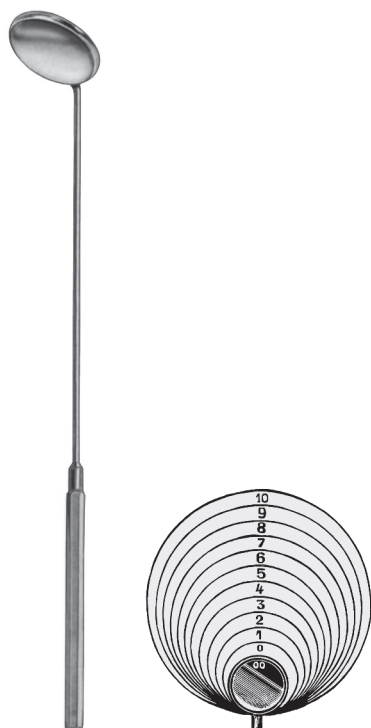

| | | |
|---------|----------------|---------|
| 35.0008 | # 000 = 6 mm Ø | 35.0028 |
| 35.0009 | # 00 = 8 mm Ø | 35.0029 |
| 35.0010 | # 0 = 10 mm Ø | 35.0030 |
| 35.0011 | # 1 = 12 mm Ø | 35.0031 |
| 35.0012 | # 2 = 14 mm Ø | 35.0032 |
| 35.0013 | # 3 = 16 mm Ø | 35.0033 |
| 35.0014 | # 4 = 18 mm Ø | 35.0034 |
| 35.0015 | # 5 = 20 mm Ø | 35.0035 |
| 35.0016 | # 6 = 22 mm Ø | 35.0036 |
| 35.0017 | # 7 = 24 mm Ø | 35.0037 |
| 35.0018 | # 8 = 26 mm Ø | 35.0038 |
| 35.0019 | # 9 = 28 mm Ø | 35.0039 |
| 35.0020 | # 10 = 30 mm Ø | 35.0040 |

35.0045

35.0047

Griff / handle / manche / mango / manico



35.0050
10 mm



35.0051
12 mm



35.0052
14 mm



35.0053
16 mm



35.0054
18 mm

MICHEL
25 cm

Rhinoskopiespiegel
 Rhinoscopic mirrors
 Miroirs rhinoscopiques
 Espejos rinoscópicos
 Specchi per rinoscopia

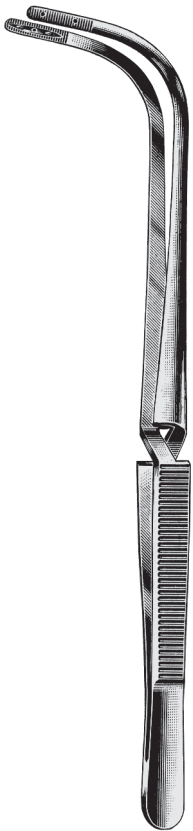

1
35.0100



2
35.0105

Tamponpinzetten
 Tampon Forceps
 Pincas porte-tampons
 Pinzas porta tampones
 Pinze per tamponi

JACKSON
22 cm

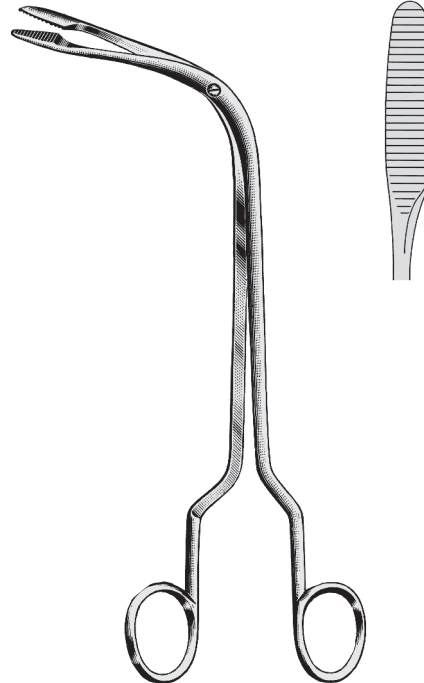

FRAENKEL
35.0110
18 cm



1
35.0120

nach rechts öffnend / opening right / ouvrant à la droite /
 abriendo hacia derecha / aprendo a destra



2
35.0121

nach links öffnend / opening left / ouvrant à la gauche /
 abriendo hacia izquierda / aprendo a sinistra



3
35.0122

nach unten öffnend / opening downward / ouvrant en bas /
 abriendo hacia abajo / aprendo in basso

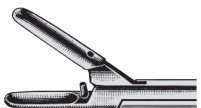

4
35.0123

nach oben öffnend / opening upward / ouvrant en haut /
 abriendo hacia arriba / aprendo in aldo



JURASZ
23 cm

KEHLKOPFZANGEN UND -DECKELHALTER
LARYNGEAL FORCEPS, EPIGLOTTIS RETRACTOR
PINCES LARYNGIENNES, DEPRESSEUR DE L'ÉPIGLOTTE
PINZAS PARA POLIPOS LARINGEOS, DEPRESOR PARA EPIGLOTIS
PINZE PER POLIPI LARINGEI, DEPRESSORE EPIGLOTTICO

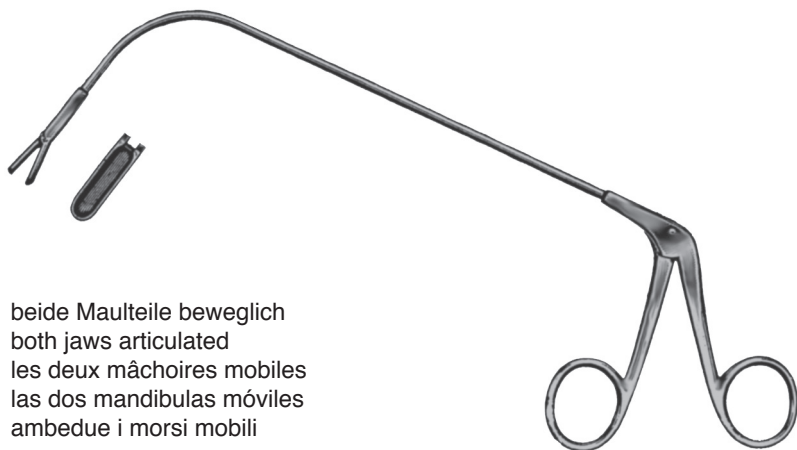

beide Maulteile beweglich
both jaws articulated
les deux mâchoires mobiles
las dos mandibulas móviles
ambedue i morsi mobili

FRAENKEL
35.0125

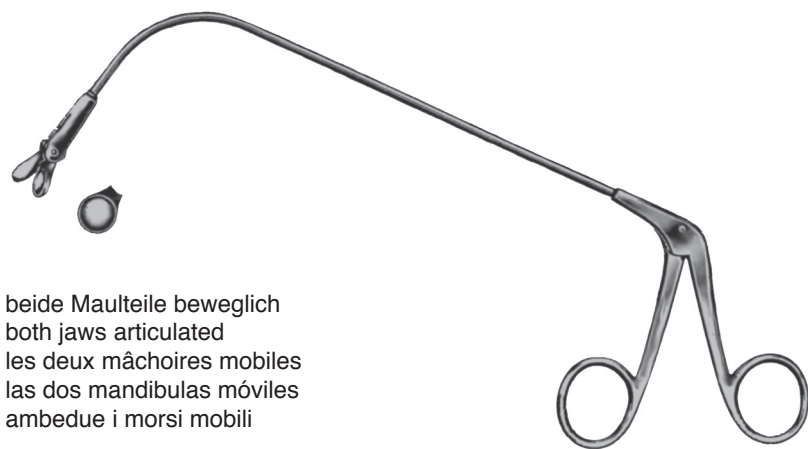

beide Maulteile beweglich
both jaws articulated
les deux mâchoires mobiles
las dos mandibulas móviles
ambedue i morsi mobili

LANGE
35.0127

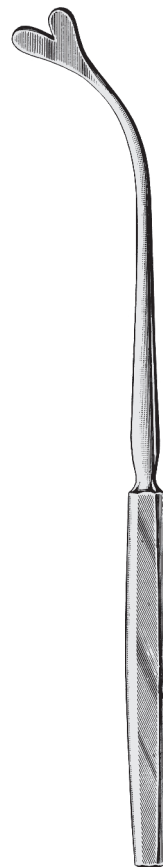

Kehlkopfdeckelhalter
Epiglottis retractor
Dépresseur de l'épiglottis
Depresor para épiglotis
Depressore epiglottico

REICHERT
35.0130
23 cm

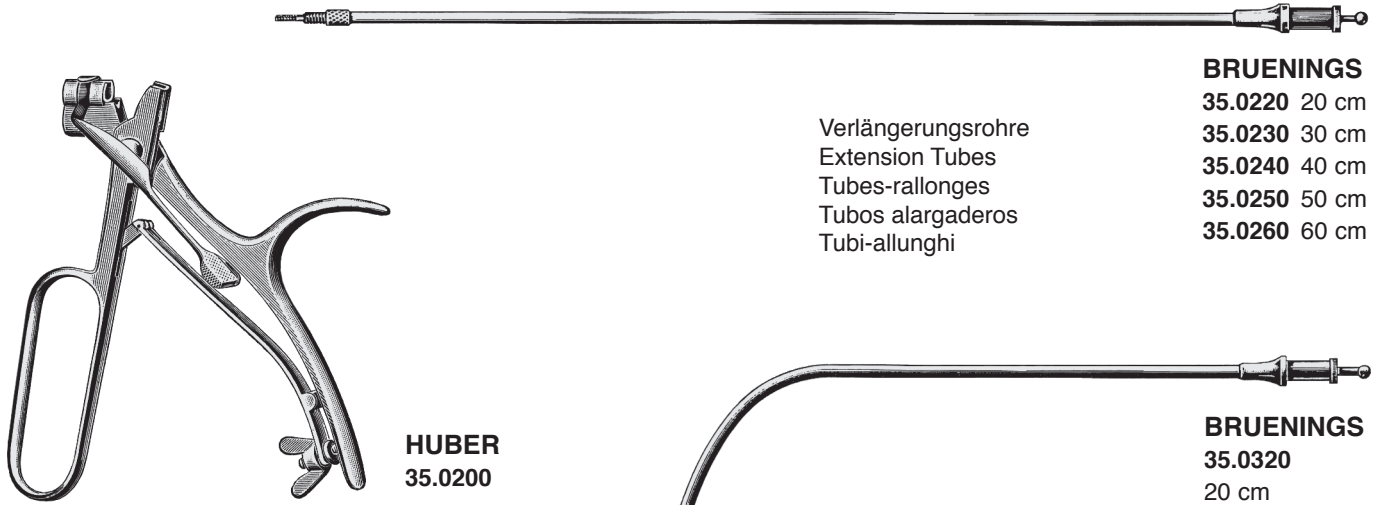

HUBER
35.0200

Universalgriff für Verlängerungsrohre 35.0220 - 35.0320
 Universal Handle for extension tubes 35.0220 - 35.0320
 Manche universel pour tubes de rallonge 35.0220 - 35.0320
 Mango universal para tubos de extension 35.0220 - 35.0320
 Manico universale per tubi allunghi 35.0220 - 35.0320

Verlängerungsrohre
 Extension Tubes
 Tubes-rallonges
 Tubos alargaderos
 Tubi-allunghi

BRUENINGS
 35.0220 20 cm
 35.0230 30 cm
 35.0240 40 cm
 35.0250 50 cm
 35.0260 60 cm

BRUENINGS
 35.0320
 20 cm

AUSWECHSELBARE ZANGENAUFsätze / EXCHANGEABLE TIPS / EMBOUTS INTERCHANGEABLES
 PINZAS INTECAMBIABLES / PINZE INTERCAMBIABILI



FRAENKEL
35.0400



SEIFFERT
35.0405



FRAENKEL
35.0420



LANGE
35.0430



BRUENINGS
 ○ 35.0440 2 mm
 ○ 35.0442 3 mm
 ○ 35.0444 4 mm



BRUENINGS
 ○ 35.0445
 3 mm



BRUENINGS
 ○ 35.0446 2 mm
 ○ 35.0448 3 mm



SCHEINMANN
35.0450



SCHEINMANN
35.0452

AUSWECHSELBARE ZANGENAUFSAETZE / EXCHANGEABLE TIPS / EMBOUTS INTERCHANGEABLES
PINZAS INTECAMBIABLES / PINZE INTERCAMBIABILI



KRAUSE

35.0460 #1



35.0461 #2



KRAUSE

35.0465



SCHUMACHER

35.0468



CORDES

35.0485 #1



35.0486 #2



CORDES

35.0487



CORDES

35.0488 #1, 3 mm



35.0489 #2, 4 mm



35.0490 #3, 5 mm



35.0491 #4, 8 mm



ROSENBERG

35.0495

Längen / Lengths / Longueurs / Largos / Lunghezze





CHEVALIER-JACKSON
 35.0603 – 35.0716

- #1  **35.0603** 30 cm
35.0604 40 cm
35.0605 50 cm
35.0606 60 cm

- #2  **35.0623** 30 cm
35.0624 40 cm
35.0625 50 cm
35.0626 60 cm

- #4  **35.0653** 30 cm
35.0654 40 cm
35.0655 50 cm
35.0656 60 cm

- #6  **35.0703** 30 cm
35.0704 40 cm
35.0705 50 cm
35.0706 60 cm

- #3  **35.0643** 30 cm
35.0644 40 cm
35.0645 50 cm
35.0646 60 cm

- #5  **35.0663** 30 cm
35.0664 40 cm
35.0665 50 cm
35.0666 60 cm

- #7  **35.0713** 30 cm
35.0714 40 cm
35.0715 50 cm
35.0716 60 cm



JACKSON
35.0750
 30 cm Ø 2,0 mm

35.0752
 35 cm Ø 2,5 mm

35.0754
 50 cm Ø 4,0 mm

35.0756
 55 cm Ø 4,0 mm

Saug- und Spülrohre
 Suction and Irrigating Tubes
 Tubes à aspiration et à lavage
 Tubos aspiradoras y irrigadoras
 Tubi aspiradore e irrigatore



ASPIRATION
35.0760
 25 cm Ø 2,0 mm

35.0762
 25 cm Ø 2,5 mm

35.0764
 25 cm Ø 3,0 mm

LARYNGO-BRONCHOSKOPIEZANGEN
 LARYNGO-BRONCHOSCOPY FORCEPS
 PINCES POUR LARYNGO-BRONCHOSCOPIE
 PINZAS PARA LARINGO-BRONCHOSCOPIA
 PINZE PER LARINGO-BRONCSCOPIA

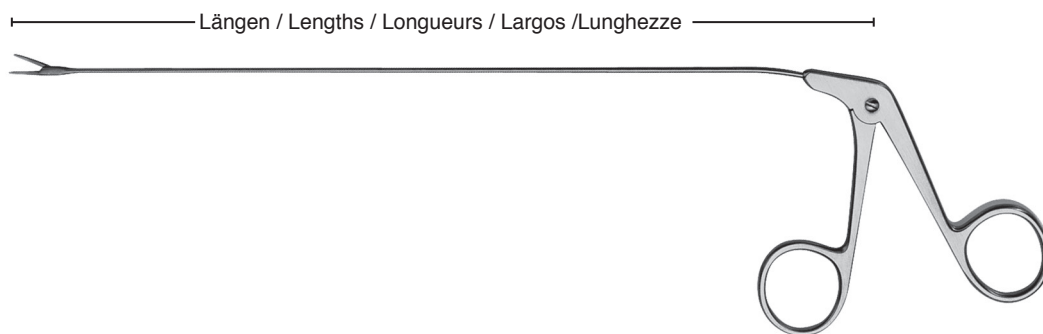

35.3600 - 35.3649

LARYNGO-Bronchoscopy

Schaft Ø 2,5 mm
 Shaft Ø 2,5 mm
 Tige Ø 2,5 mm
 Vestago Ø 2,5 mm
 Asta Ø 2,5 mm

| | 40 cm | 50 cm | 60 cm |
|--|--------------|--------------|-------------|
| | 35.3600 # 0 | 35.3620 # 0 | 35.3640 # 0 |
| | 35.3601 # 1 | 35.3621 # 1 | 35.3641 # 1 |
| | 35.3602 # 2 | 35.3622 # 2 | 35.3642 # 2 |
| | 35.3603 # 3 | 35.3623 # 3 | 35.3643 # 3 |
| | 35.3604 # 4 | 35.3624 # 4 | 35.3644 # 4 |
| | 35.3605 # 5 | 35.3625 # 5 | 35.3645 # 5 |
| | 35.3606 # 6 | 35.3626 # 6 | 35.3646 # 6 |
| | 35.3607 # 7 | 35.3627 # 7 | 35.3647 # 7 |
| | 35.3608 # 8 | 35.3628 # 8 | 35.3648 # 8 |
| | 35.3609 # 9 | 35.3629 # 9 | 35.3649 # 9 |
| | 35.3610 # 10 | 35.3630 # 10 | |
| | 35.3611 # 11 | 35.3631 # 11 | |
| | 35.3612 # 12 | 35.3632 # 12 | |



McINTOSH

11.1002

Besteck bestehend aus: 11.1016 Batteriegriff 30 mm (ohne Batterien), 11.1020 McIntosh Spatel Fig. 0, 11.1021 dito Fig. 1, 11.1022 dito Fig. 2, 11.1027 Etui für 3 Spateln

Set consisting of: 11.1016 Battery Handle 30 mm (without batteries), 11.1020 McIntosh Blade Fig. 0, 11.1021 dito Fig. 1, 11.1022 dito Fig. 2, 11.1027 Case for 3 blades

Trousse, composée de: 11.1016 Manche à piles 30 mm (sans piles), 11.1020 McIntosh Spatule Fig. 0, 11.1021 dito Fig. 1, 11.1022 dito Fig. 2, 11.1027 Etui pour 3 spatules

Juego compuesto de: 11.1016 Mango de pila 30 mm (sin pilas), 11.1020 McIntosh Hoja Fig. 0, 11.1021 idem Fig. 1, 11.1022 idem Fig. 2, 11.1027 Estuche para 3 hojas

Set completo composta da: 11.1016 Manico per pila 30 mm (senza pila), 11.1021 McIntosh Spatola Fig. 0, 11.1021 idem Fig. 1, 11.1022 idem Fig. 2, 11.1027 astuccio per 3 spatole

McINTOSH

11.1003

Besteck bestehend aus: 11.1016 Batteriegriff (ohne Batterie), 11.1021 McINTOSH Spatel Fig. 1, 11.1022 dito Fig. 2, 11.1023 dito Fig. 3, 11.1027 Etui für 3 Spatel

Set consisting of 11.1016 Battery Handle (without batteries), 11.1021 McINTOSH Blade Fig. 1, 11.1022 dito Fig. 2, 11.1023 dito Fig. 3, 11.1027 Case for 3 blades

Trousse, composée de 11.1016 Manche à piles (sans piles), 11.1021 McINTOSH Spatule Fig. 1, 11.1022 dito Fig. 2, 11.1023 dito Fig. 3, 11.1027 Etui pour 3 spatules

Juego compuesto de: 11.1016 Mango de pila (sin pilas), 11.1021 McINTOSH Hoja Fig. 1, 11.1022 idem Fig. 2, 11.1023 idem Fig. 3, 11.1027 Estuche para 3 hojas

Set completo composto da: 11.1016 Manico per pila 30 mm (senza pila); 11.1021 McIntosh Spatola Fig. 1; 11.1022 idem Fig. 2; 11.1023 idem Fig. 3; 11.1027 astuccio per 3 spatole.



McINTOSH

11.1004

Besteck bestehend aus: 11.1016 Batteriegriff (ohne Batterie), 11.1021 McINTOSH Spatel Fig. 1, 11.1022 dito Fig. 2, 11.1023 dito Fig. 3, 11.1024 dito Fig. 4 11.1028 Etui für 4 Spatel

Set consisting of 11.1016 Battery Handle (without batteries), 11.1021 McINTOSH Blade Fig. 1, 11.1022 dito Fig. 2, 11.1023 dito Fig. 3, 11.1024 dito Fig. 4, 11.1028 Case for 4 blades

Trousse, composée de 11.1016 Manche à piles (sans piles), 11.1021 McINTOSH Spatule Fig. 1, 11.1022 dito Fig. 2, 11.1023 dito Fig. 3, 11.1024 dito Fig. 4, 11.1028 Etui pour 4 spatules

Juego compuesto de: 11.1016 Mango de pila (sin pilas), 11.1021 McINTOSH Hoja Fig. 1, 11.1022 idem Fig. 2, 11.1023 idem Fig. 3, 11.1024 idem Fig. 4, 11.1028 Estuche para 4 hojas

Set completo composto da: 11.1016 Manico per pila 30 mm (senza pila); 11.1021 McIntosh Spatola Fig. 1; 11.1022 idem Fig. 2; 11.1023 idem Fig. 3; 11.1024 idem Fig. 4; 11.1028 astuccio per 4 spatole.



McINTOSH

11.1005

Besteck bestehend aus: 11.1016 Batteriegriff 30 mm (ohne Batterien), 11.1020 McIntosh Spatel Fig. 0, 11.1021 dito Fig. 1, 11.1022 dito Fig. 2, 11.1023 dito Fig. 3, 11.1024 dito Fig. 4, 11.1027 Etui für 3 Spateln, Etui

Set consisting of: 11.1016 Battery Handle 30 mm (without batteries), 11.1020 McIntosh Blade Fig. 0, 11.1021 dito Fig. 1, 11.1022 dito Fig. 2, 11.1023 dito Fig. 3, 11.1024 dito Fig. 4, Case

Trousse, composée de: 11.1016 Manche à piles 30 mm (sans piles), 11.1020 McIntosh Spatule Fig. 0, 11.1021 dito Fig. 1, 11.1022 dito Fig. 2, 11.1023 dito Fig. 3, 11.1024 dito Fig. 4, Etui

Juego compuesto de: 11.1016 Mango de pila 30 mm (sin pilas), 11.1020 McIntosh Hoja Fig. 0, 11.1021 idem Fig. 1, 11.1022 idem Fig. 2, 11.1023 idem Fig. 3, 11.1024 idem Fig. 4, Estuche

Set completo composta da: 11.1016 Manico per pila 30 mm (senza pila), 11.1020 McIntosh Spatola Fig. 0, 11.1021 idem Fig. 1, 11.1022 idem Fig. 2, 11.1023 idem Fig. 3, 11.1024 idem Fig. 4, astuccio



11.1016

Batteriegriff 30 mm Ø (ohne Batterien)
Battery handle 30 mm Ø (without batteries)
Manche à pile 30 mm Ø (sans piles)
Mango de pilas 30 mm Ø (sin pilas)
Manico per pila 30 mm Ø (senza pila)



11.1017

Batteriegriff 18 mm Ø (ohne Batterien)
Battery handle 18 mm Ø (without batteries)
Manche à pile 18 mm Ø (sans piles)
Mango de pilas 18 mm Ø (sin pilas)
Manico per pila 18 mm Ø (senza pila)



11.1018

Ersatzbirne, klein für Spateln Fig. 0 - 1
Spare Bulb, small for blades Fig. 0 - 1
Ampoule de rechange, petit, pour spatules Fig. 0 - 1
Bombilla de ricambio, pequeño, para hojas Fig. 0 - 1
Lampadina di ricambio, piccolo, per spatole Fig. 0 - 1



11.1019

Ersatzbirne, groß, für Spateln Fig 2 - 4
Spare Bulb, large, for blades Fig. 1 - 4
Ampoule de rechange, grand, pour spatules Fig. 2 - 4
Bombilla de ricambio, grande, para hojas Fig. 2 - 4
Lampadina di ricambio, grande, per spatole Fig. 2 - 4



McINTOSH
11.1020
 55 mm Fig. 0

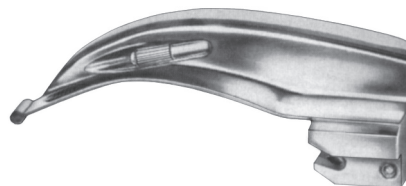

McINTOSH
11.1021
 75 mm Fig. 1



McINTOSH
11.1022
 90 mm Fig. 2



McINTOSH
11.1023
 110 mm Fig. 3



McINTOSH
11.1024
 130 mm Fig. 4



MILLER-BABY

11.1052

Besteck bestehend aus: 11.1016 Batteriegriff (ohne Batterien),
 11.1070 MILLER-BABY Spatel Fig. 0, 11.1071 dito Fig. 1

Set consisting of: 11.1016 Battery handle (without batteries),
 11.1071 MILLER-BABY Spatula Fig. 0, 11.1071 ditto Fig. 1

Trousse, composée de: 11.1016 Manche à piles (sans piles),
 11.1070 spatule MILLER-BABY Fig. 0, 11.1071 dito Fig. 1

Juego compuesto de: 11.1016 Mango de pilas (sin pilas),
 11.1070 hoja MILLER-BABY Fig. 0, 11.1071 idem Fig. 1

Set completo composto da: 11.1016 Manico per pila 30 mm (senza
 pila), 11.1070 MILLER-BABY spatola Fig. 0, 11.1071 idem Fig. 1



MILLER

11.1063

Laryngoskop 3 Spateln Figur 1 - 3

Besteck bestehend aus: 11.1016 Batteriegriff (ohne Batterien), 11.1071 MILLER Spatel Fig. 1; 11.1072 dito Fig. 2, 11.1073 dito Fig. 3, Etui

Set consisting of: 11.1016 Battery handle (without batteries), 11.1071 MILLER Spatula Fig. 1, 11.1072 Fig. 2, 11.1073 ditto Fig. 3, case

Trousse, composée de: 11.1016 Manche à piles (sans piles), 11.1071 spatule MILLER Fig. 1, 11.1072 dito Fig. 2, 11.1073 dito Fig. 3, Etui

Juego compuesto de: 11.1016 Mango de pilas (sin pilas), 11.1071 hoja MILLER Fig. 1, 11.1072 idem Fig. 2; 11.1073 idem Fig. 3, Estuche

Set completo composto da: 11.1016 Manico per pila 30 mm (senza pila), 11.1071 MILLER spatola Fig. 1; 11.1072 idem Fig. 2, 11.1073 idem Fig. 3, astucchio

MILLER

11.1064

Laryngoskop 4 Spateln Figur 1 - 4

Besteck bestehend aus: 11.1016 Batteriegriff (ohne Batterien), 11.1071 MILLER Spatel Fig. 1, 11.1072 dito Fig. 2, 11.1073 dito Fig. 3, 11.1074 dito Fig. 4, Etui

Set consisting of: 11.1016 Battery handle (without batteries), 11.1071 MILLER Spatula Fig. 1, 11.1072 Fig. 2, 11.1073 ditto Fig. 3, 11.1074 ditto Fig. 4, case

Trousse, composée de: 11.1016 Manche à piles (sans piles), 11.1071 spatule MILLER Fig. 1, 11.1072 dito Fig. 2, 11.1073 dito Fig. 3, 11.1074 dito Fig. 4, Etui

Juego compuesto de: 11.1016 Mango de pilas (sin pilas), 11.1071 hoja MILLER Fig. 1, 11.1072 idem Fig. 2, 11.1073 idem Fig. 3, 11.1074 idem Fig. 4, Estuche

Set completo composto da: 11.1016 Manico per pila 30 mm (senza pila), 11.1071 MILLER spatola Fig. 1, 11.1072 idem Fig. 2, 11.1073 idem Fig. 3, 11.1074 idem Fig. 4, astucchio

MILLER

11.1065

Laryngoskop 5 Spateln Figur 0 - 4

Besteck bestehend aus: 11.1016 Batteriegriff (ohne Batterien), 11.1070 MILLER Spatel Fig. 0; 11.1071 dito Fig. 1, 11.1072 dito Fig. 2, 11.1073 dito Fig. 3, 11.1074 dito Fig. 4, Etui

Set consisting of: 11.1016 Battery handle (without batteries), 11.1070 MILLER Spatula Fig. 0, 11.1071 Fig. 1, 11.1072 Fig. 2, 11.1073 ditto Fig. 3, 11.1074 ditto Fig. 4, case

Trousse, composée de: 11.1016 Manche à piles (sans piles), 11.1070 spatule MILLER Fig. 0, 11.1071 dito Fig. 1, 11.1072 dito Fig. 2, 11.1073 dito Fig. 3, 11.1074 dito Fig. 4, Etui

Juego compuesto de: 11.1016 Mango de pilas (sin pilas), 11.1070 hoja MILLER Fig. 0, 11.1071 idem Fig. 1, 11.1072 idem Fig. 2, 11.1073 idem Fig. 3, 11.1074 idem Fig. 4, Estuche

Set completo composto da: 11.1016 Manico per pila 30 mm (senza pila), 11.1070 MILLER spatola Fig. 0, 11.1071 idem Fig. 1, 11.1072 idem Fig. 2, 11.1073 idem Fig. 3, 11.1074 idem Fig. 4, astucchio



11.1016
30 mm Ø
ohne Batterien
without batteries
sans piles
sin pilas
senza pila

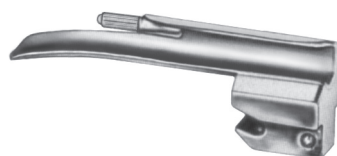

MILLER-BABY
11.1070
55 mm Fig. 0



MILLER-BABY
11.1071
80 mm Fig. 1



MILLER
11.1072
130 mm Fig. 2



MILLER
11.1073
170 mm Fig. 3



MILLER
11.1074
180 mm Fig. 4



WISCONSIN-FOREGGER

11.1103

Laryngoskop 3 Spateln

Besteck bestehend aus: 11.1016 Batteriegriff (ohne Batterien), 11.1111 Foregger Spatel Fig. 1, 11.1112 dito Fig. 2, 11.1113 dito Fig. 3, Etui

Set consisting of: 11.1016 Battery handle (without batteries), 11.1111 Foregger Spatula Fig. 1, 11.1112 Fig. 2, 11.1113 ditto Fig. 3, case

Trousse, composée de: 11.1016 Manche à piles (sans piles), 11.1111 spatule Foregger Fig. 1, 11.1112 dito Fig. 2, 11.1113 dito Fig. 3, Etui

Juego compuesto de: 11.1016 Mango de pilas (sin pilas), 11.1111 hoja Foregger Fig. 1, 11.1112 idem Fig. 2, 11.1113 idem Fig. 3, Estuche

Set completo composto da: 11.1016 Manico per pila 30 mm (senza pila), 11.1111 Foregger spatola Fig. 1, 11.1112 idem Fig. 2, 11.1113 idem Fig. 3, astucchio



WISCONSIN-FOREGGER

11.1104

Laryngoskop 4 Spateln

Besteck bestehend aus: 11.1016 Batteriegriff (ohne Batterien), 11.1111 Foregger Spatel Fig. 1, 11.1112 dito Fig. 2, 11.1113 dito Fig. 3, 11.1114 dito Fig. 4, Etui

Set consisting of: 11.1016 Battery handle (without batteries), 11.1111 Foregger Spatula Fig. 1, 11.1112 Fig. 2, 11.1113 ditto Fig. 3, 11.1114 ditto Fig. 4, case

Trousse, composée de: 11.1016 Manche à piles (sans piles), 11.1111 spatule Foregger Fig. 1, 11.1112 dito Fig. 2, 11.1113 dito Fig. 3, 11.1114 dito Fig. 4, Etui

Juego compuesto de: 11.1016 Mango de pilas (sin pilas), 11.1111 hoja Foregger Fig. 1, 11.1112 idem Fig. 2, 11.1113 idem Fig. 3, 11.1114 idem Fig. 4, Estuche

Set completo composto da: 11.1016 Manico per pila 30 mm (senza pila), 11.1111 Foregger spatola Fig. 1, 11.1112 idem Fig. 2, 11.1113 idem Fig. 3, 11.1114 idem Fig. 4, astucchio



WISCONSIN-FOREGGER

11.1111

70 mm Fig. 1



WISCONSIN-FOREGGER

11.1113

110 mm Fig. 3



WISCONSIN-FOREGGER

11.1112

90 mm Fig. 2



WISCONSIN-FOREGGER

11.1114

135 mm Fig. 4





GEUDEL-NEGUS

11.1123

Laryngoskop 3 Spateln

Besteck bestehend aus: 11.1016 Batteriegriff (ohne Batterien), 11.1132 Geudel-Negus Spatel Fig. 2, 11.1133 dito Fig. 3, 11.1134 dito Fig. 4, Etui

Set consisting of: 11.1016 Battery handle (without batteries), 11.1132 Geudel-Negus Spatula Fig. 2, 11.1133 Fig. 3, 11.1134 ditto Fig. 4, case

Trousse, composée de: 11.1016 Manche à piles (sans piles), 11.1132 spatule Geudel-Negus Fig. 2, 11.1133 ditto Fig. 3, 11.1134 ditto Fig. 4, Etui

Juego compuesto de: 11.1016 Mango de pilas (sin pilas), 11.1132 hoja Geudel-Negus Fig. 2, 11.1133 idem Fig. 3, 11.1134 idem Fig. 4, Estuche

Set completo composto da: 11.1016 Manico per pila 30 mm (senza pila), 11.1132 Geudel-Negus spatola Fig. 2, 11.1133 idem Fig. 3, 11.1134 idem Fig. 4, astucchio



GEUDEL-NEGUS

11.1124

Laryngoskop 4 Spateln

Besteck bestehend aus: 11.1016 Batteriegriff (ohne Batterien), 11.1131 Geudel-Negus Spatel Fig. 1, 11.1132 ditto Fig. 2, 11.1133 ditto Fig. 3, 11.1134 ditto Fig. 4, Etui

Set consisting of: 11.1016 Battery handle (without batteries), 11.1131 Geudel-Negus Spatula Fig. 1, 11.1132 ditto Fig. 2, 11.1133 Fig. 3, 11.1134 ditto Fig. 4, case

Trousse, composée de: 11.1016 Manche à piles (sans piles), 11.1131 spatule Geudel-Negus Fig. 1, 11.1132 ditto Fig. 2, 11.1133 ditto Fig. 3, 11.1134 ditto Fig. 4, Etui

Juego compuesto de: 11.1016 Mango de pilas (sin pilas), 11.1131 hoja Geudel-Negus Fig. 1, 11.1132 idem Fig. 2, 11.1133 idem Fig. 3, 11.1134 idem Fig. 4, Estuche

Set completo composto da: 11.1016 Manico per pila 30 mm (senza pila), 11.1131 Geudel-Negus spatola Fig. 1, 11.1132 idem Fig. 2, 11.1133 idem Fig. 3, 11.1134 idem Fig. 4, astucchio



GEUDEL-NEGUS

11.1131

70 mm Fig. 1



GEUDEL-NEGUS

11.1132

90 mm Fig. 2



GEUDEL-NEGUS

11.1133

110 mm Fig. 3



GEUDEL-NEGUS

11.1134

135 mm Fig. 4



McINTOSH

11.2003

Laryngoskop 3 Spateln

Besteck bestehend aus: 11.2016 Batteriegriff (ohne Batterien), 11.2021 McINTOSH Spatel Fig. 1, 11.2022 dito Fig. 2, 11.2023 dito Fig. 3, 11.1027 Etui

Set consisting of: 11.2016 Battery handle (without batteries), 11.2021 McINTOSH Spatula Fig. 1, 11.2022 Fig. 2, 11.2023 dito Fig. 3, 11.1027 case

Trousse, composée de: 11.2016 Manche à piles (sans piles), 11.2021 spatule McINTOSH Fig. 1, 11.2022 dito Fig. 2, 11.2023 dito Fig. 3, 11.1027 Etui

Juego compuesto de: 11.2016 Mango de pilas (sin pilas), 11.2021 hoja McINTOSH Fig. 1, 11.2022 idem Fig. 2, 11.2023 idem Fig. 3, 11.1027 Estuche

Set completo composto da: 11.2016 Manico per pila 30 mm (senza pila), 11.2021 McINTOSH spatola Fig. 1, 11.2022 idem Fig. 2, 11.2023 idem Fig. 3, 11.1027 astucchio

McINTOSH

11.2004

Laryngoskop 4 Spateln

Besteck bestehend aus: 11.2016 Batteriegriff (ohne Batterien), 11.2021 McINTOSH Spatel Fig. 1, 11.2022 dito Fig. 2, 11.2023 dito Fig. 3, 11.2024 dito Fig. 4; 11.1027 Etui

Set consisting of: 11.2016 Battery handle (without batteries), 11.2021 McINTOSH Spatula Fig. 1, 11.2022 Fig. 2, 11.2023 dito Fig. 3, 11.2024 dito Fig. 4, 11.1027 case

Trousse, composée de: 11.2016 Manche à piles (sans piles), 11.2021 spatule McINTOSH Fig. 1, 11.2022 dito Fig. 2, 11.2023 dito Fig. 3, 11.2024 dito Fig. 4, 11.1027 Etui

Juego compuesto de: 11.2016 Mango de pilas (sin pilas), 11.2021 hoja McINTOSH Fig. 1, 11.2022 idem Fig. 2, 11.2023 idem Fig. 3, 11.2024 idem Fig. 4; 11.1027 Estuche

Set completo composto da: 11.2016 Manico per pila 30 mm (senza pila), 11.2021 McINTOSH spatola Fig. 1, 11.2022 idem Fig. 2, 11.2023 idem Fig. 3, 11.2024 idem Fig. 4, 11.1027 astucchio



11.2016

Batteriegriff 30 mm Ø (ohne Batterien)
Battery handle 30 mm Ø (without batteries)
Manche à pile 30 mm Ø (sans piles)
Mango de pilas 30 mm Ø (sin pilas)
Manico per pila 30 mm Ø (senza pila)

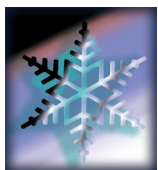

11.2016

Batteriegriff 30 mm Ø (ohne Batterien)
Battery handle 30 mm Ø (without batteries)
Manche à pile 30 mm Ø (sans piles)
Mango de pilas 30 mm Ø (sin pilas)
Manico per pila 30 mm Ø (senza pila)



11.2018

Kaltlicht-Ersatzlampe
Fiber optic spare bulb
lumière froide Ampoule de rechange
luz fria bombilla de ricambio
luce fredda lampadina di ricambio



**McINTOSH
11.2020**

55 mm Fig. 0



**McINTOSH
11.2021**

70 mm Fig. 1



**McINTOSH
11.2022**

90 mm Fig. 2



**McINTOSH
11.2023**

105 mm Fig. 3



**McINTOSH
11.2024**

130 mm Fig. 4



MILLER

11.2063

Laryngoskop 3 Spateln

Besteck bestehend aus: 11.2016 Batteriegriff (ohne Batterien), 11.2071 Miller Spatel Fig. 1, 11.2072 dito Fig. 2, 11.2073 dito Fig. 3, Etui

Set consisting of: 11.2016 Battery handle (without batteries), 11.2071 Miller Spatula Fig. 1, 11.2072 Fig. 2, 11.2073 ditto Fig. 3, case

Trousse, composée de: 11.2016 Manche à piles (sans piles), 11.2071 spatule Miller Fig. 1, 11.2072 dito Fig. 2, 11.2073 dito Fig. 3, Etui

Juego compuesto de: 11.2016 Mango de pilas (sin pilas), 11.071 hoja Miller Fig. 1, 11.2072 idem Fig. 2, 11.2073 idem Fig. 3, Estuche

Set completo composto da: 11.2016 Manico per pila 30 mm (senza pila), 11.2071 Miller spatola Fig. 1, 11.2072 idem Fig. 2, 11.2073 idem Fig. 3, astucchio

MILLER

11.2064

Laryngoskop 4 Spateln

Besteck bestehend aus: 11.2016 Batteriegriff (ohne Batterien), 11.2071 Miller Spatel Fig. 1, 11.2072 dito Fig. 2, 11.2073 dito Fig. 3, 11.2073 dito Fig. 4, Etui

Set consisting of: 11.2016 Battery handle (without batteries), 11.2071 Miller Spatula Fig. 1, 11.2072 Fig. 2, 11.2073 ditto Fig. 3, 11.2074 ditto Fig. 4, case

Trousse, composée de: 11.2016 Manche à piles (sans piles), 11.2071 spatule Miller Fig. 1, 11.2072 dito Fig. 2, 11.2073 dito Fig. 3, 11.2074 dito Fig. 4, Etui

Juego compuesto de: 11.2016 Mango de pilas (sin pilas), 11.071 hoja Miller Fig. 1, 11.2072 idem Fig. 2, 11.2073 idem Fig. 3, 11.2074 idem Fig. 4, Estuche

Set completo composto da: 11.2016 Manico per pila 30 mm (senza pila), 11.2071 Miller spatola Fig. 1, 11.2072 idem Fig. 2, 11.2073 idem Fig. 3, 11.2074 idem Fig. 4, astucchio

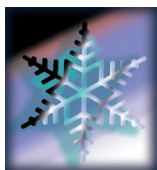

11.2016

Batteriegriff 30 mm Ø (ohne Batterien)
Battery handle 30 mm Ø (without batteries)
Manche à pile 30 mm Ø (sans piles)
Mango de pilas 30 mm Ø (sin pilas)
Manico per pila 30 mm Ø (senza pila)



11.2018

Kaltlicht-Ersatzlampe
Fiber optic spare bulb
lumière froide Ampouule de rechange
luz fria bombilla de ricambio
luce fredda lampadina di ricambio



MILLER-BABY

11.2070

55 mm Fig. 0



MILLER-BABY

11.2071

80 mm Fig. 1



MILLER

11.2072

130 mm Fig. 2



MILLER

11.2073

170 mm Fig. 3



MILLER

11.2074

180 mm Fig. 4



35.2000

135 mm

für Kinder, sehr klein

for infants, very small

pour enfants, très petite section

para niños, muy pequeño

per bambini, molto piccolo



35.2002

152 mm

für Kinder, klein

for children, small

pour enfants, petite section

para niños, pequeño

per bambini, piccolo

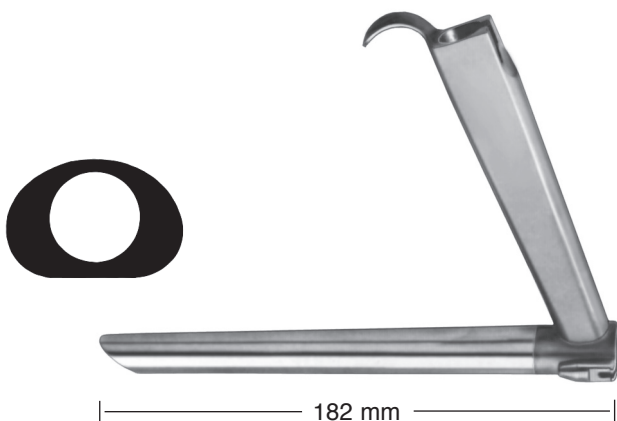

35.2004

182 mm

für Jugendliche, klein

for adolescents, small

pour Jeunes, petite section

para menores, pequeño

per giovane, piccolo



35.2006

172 mm

für Erwachsene, mittel

for adults, medium

pour adultes, section moyenne

para adultos, medio

per adulti, mediocre



35.2008
172 mm
für Erwachsene, gross
for adults, large
pour adultes, section large
para adultos, grande
per adulti, grande

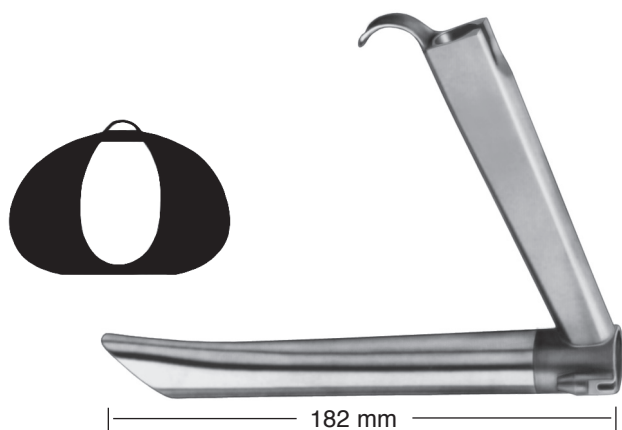

35.2010
182 mm
für Erwachsene, gross
for adults, large
pour adultes, section large
para adultos, grande
per adulti, grande

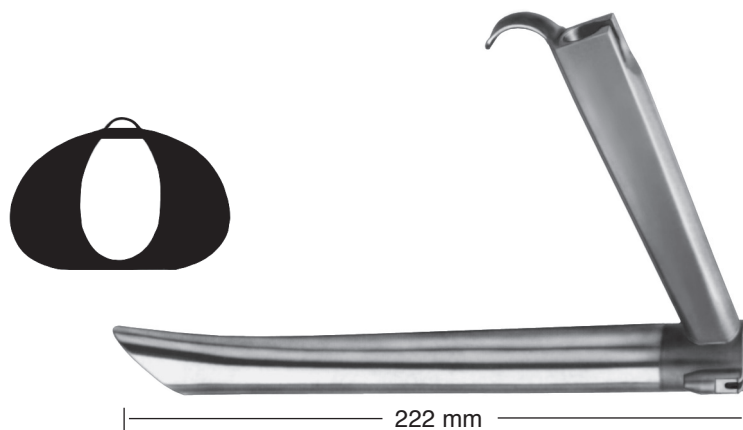

35.2012
222 mm
Hypopharyngoskop, für die vordere Kommissur
Hypopharyngoscope, for anterior commissure
Hypopharyngoscope, pour la commissure antérieure
Hipofaringoscopia, para la comisura anterior
Hipofaringoscopia, per la commissura anteriore

Unsere Fiberglass-Lichtträger werden mit Adaptern für "ACMI, STORZ, WOLF" geliefert
Our fiberglass light carriers are supplied with "ACMI, STORZ, WOLF" adapters
Nos Portes-fibre sont munis avec adapteurs "ACMI, STORZ, WOLF"
Nuestros portas luz fria se entregan con adaptadores "ACMI, STORZ, WOLF"
Nostrì condottieri di luce fredda sono corredati con un adattatore "ACMI, STORZ, WOLF"



35.2030

FIBERGLAS-Lichtträger für Laryngoskope 35.2000, 35.2002
FIBERLIGHT Carrier for Laryngoscopes 35.2000, 35.2002
PORTE FIBRE pour Spatules 35.2000, 35.2002
PORTA Luz fria para Spatulas 35.2000, 35.2002
Porta luce fredda per spatole 35.2000, 35.2002



35.2032

FIBERGLAS-Lichtträger für Laryngoskope 35.2004 - 35.2010
FIBERLIGHT Carrier for Laryngoscopes 35.2004 - 35.2010
PORTE FIBRE pour Spatules 35.2004 - 35.2010
PORTA Luz fria para Spatulas 35.2004 - 35.2010
Porta luce fredda per spatole 35.2004 - 35.2010



35.2040

INJEKTIONSKANÜLE für 35.2000 - 35.2010
INJECTION CANULA for Laryngoscope 35.2000 - 35.2010
CANULE pour injections pour 35.2000 - 35.2010
CANULA a iniecciones para 35.2000 - 35.2010
Cannula per iniezione per laringoscopi 35.2000 - 35.2010



35.2034

FIBERGLAS-Lichtträger für Laryngoskope 35.2012
FIBERLIGHT Carrier for Laryngoscopes 35.2012
PORTE FIBRE pour Spatules 35.2012
PORTA Luz fria para Spatulas 35.2012
Porta luce fredda per spatole 35.2012



35.2050

RAUCHABSAUGROHR für 35.2000-35.2010
SUCTION TUBE for 35.2000 - 35.2010
CANULE à aspiration pour 35.2000 - 35.2010
CANUA a aspiracion para 35.2000 - 35.2010
Cannula per aspirazione per laringoscopi 35.2000 - 35.2010

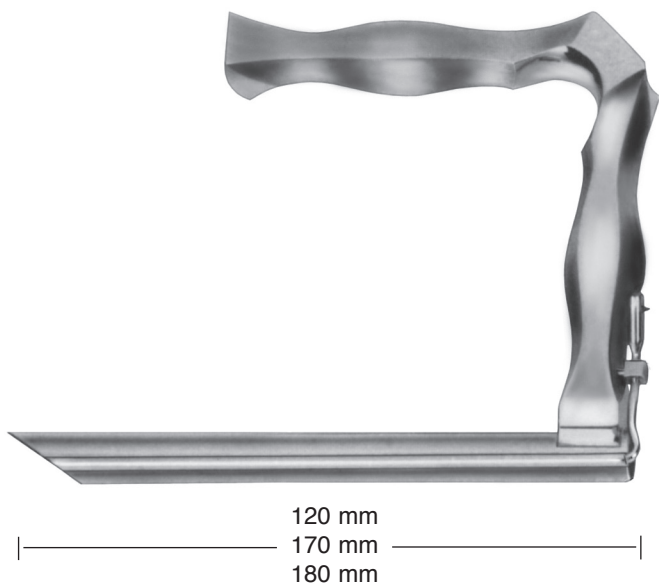

JACKSON
35.2100
120 mm
für Säuglinge
for infants
pour nourrissons
para lactantes
per neonati

JACKSON
35.2102
170 mm
für Kinder
child size
pour enfants
para niños
per bambini

JACKSON
35.2104
180 mm
für Erwachsene
for adults
pour adultes
para adultos
per adulti

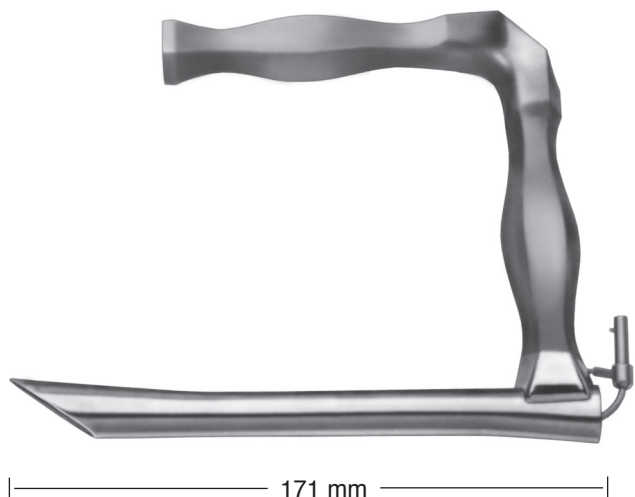

HOLINGER
35.2120
171 mm

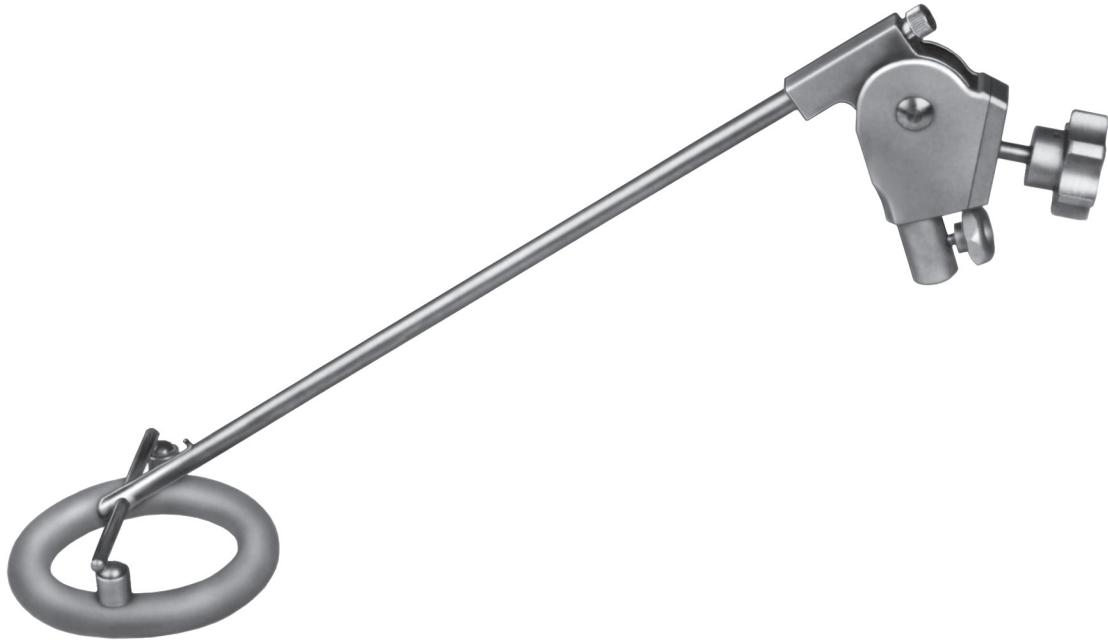

35.2020

BRUSTSTÜTZE mit Stützstange 34 cm für Erwachsene
Chest Support and Support-rod 34 cm for adults
Appui pectoral avec tige 34 cm pour adultes
Apoyo-pecho con pertiga 34 cm para adultos
Sopporto per petto per laringoscopi per adulti 34 cm

35.2025

STÜTZSTANGE für Kinder 24 cm
Support-rod for Children 24 cm
Tige-support pour enfants 24 cm
Pertiga-soporte para niños 24 c
Sopporto per petto per laringoscopi per bambini 24 cm

PRO-MED ist Ihnen behilflich bei der Zusammenstellung von Operationsbestecken für die verschiedensten Disziplinen. Fragen Sie nach unseren vorbereiteten OP-Bestecken.

For your convenience a wide variety of Suggested Operating Sets for most general and specialized procedures is available from **PRO-MED**. Please contact us or your local dealer.

PRO-MED vous propose de multiples compositions de boîtes opératoires multidisciplinaires.
Demandez nos suggestions pour de nombreuses interventions.

PRO-MED le ayuda en componer varias cajas de instrumentos quirúrgicos.
Pregunte por nuestro instrumental quirúrgico preparado.

Per la vostra comodità **PRO-MED** Vi aiuta nella raccolta di strumenti chirurgici per le varie discipline. Vi preghiamo di chiedere informazioni sui nostri set di strumenti chirurgici già preparati.

